



Foster 

Live the Quality

freestanding



freestanding

Soluzioni Cottura - Cooking Solutions

p. 07

Soluzioni Lavaggio - Washing Solutions

p. 22

Aspirazione - Aspiration

p. 30





Molto più di una cucina freestanding

I centri funzionali a libera installazione di Foster sono manufatti di alta sartorialità capaci da soli di creare un concept non convenzionale, destrutturato, funzionale, unico. Gioielli senza tempo a cui abbinare in piena libertà ogni tipo di arredamento.



Much more than just a freestanding kitchen

The Foster freestanding functional units are highly sartorial objects, which create by themselves an original kitchen concept: unstructured, functional, unique. Timeless jewels to be coupled to any kind of furniture.



Foster Milano



Acciaio lavorato a mano

Performance elevate, materiali selezionati, finiture di pregio e dettagli di classe. La nuova collezione freestanding racchiude tutto questo grazie ad una tecnologia d'avanguardia che si aggiunge alla grande maestria artigianale di Foster nelle lavorazioni dell'acciaio.

Handcrafted stainless steel

High performance, selected materials, precious finishing, classy details. The new freestanding collection holds them all, thanks to a cutting-edge technology that adds to Foster's great craftsmanship in steelwork.





Potenza di fuoco

I blocchi cottura Foster rendono la vostra cucina un performante centro di lavoro. Dotazioni professionali e misure oltre lo standard caratterizzano sia il piano cottura che il forno, per una praticità assoluta in ogni situazione.

Fire power

The Foster range-tops transform your kitchen into a high-performance work-centre. Uncommon features and oversized dimensions characterize both the range-tops and the ovens, granting absolute practicality in any situation.

Caratteristiche piani gas

Gas cooker hobs features

La griglia in ghisa ha dimensioni straordinarie e crea una superficie di lavoro fino al 50% più grande rispetto ad un normale piano domestico. Adesso è possibile utilizzare tutti i bruciatori anche con pentole di grandi dimensioni.

The weighty enamelled cast iron grid has extraordinary dimensions, with a working surface up to 50% bigger compared to a normal domestic cookerhob. It is now possible to use all the burners at the same time also with large pots.



La manopola in metallo è molto comoda grazie al cruscotto inclinato. Le dimensioni generose e la particolare forma ergonomica sono sinonimo di praticità. È presente sul forno e sul banco rubinetteria del blocco lavaggio in perfetto family feeling.

The satin-finish metal knobs show great advantage thanks to the inclination of the control board. Their generous size and original shape guarantee an easy and safe grip. They are present on the oven and graces the tap area of the sink, in perfect family feeling.



Nei blocchi con i fuochi in linea il piano di lavoro è arricchito dall'elegante "banco attrezzato", ove trovano alloggio gli elementi più usati durante la cottura: sale, spezie, olio sono così sempre a portata di mano.

The Cooking centers with the inline burners are enriched by the elegant "back shelf" on which the most commonly used products can be stored: salt, spices and oil can thus be always at hand.



I bruciatori AE (alta efficienza) sono di ultima generazione e garantiscono un risparmio del 25% rispetto a bruciatori standard. Oltre all'efficienza la potenza. Tutti i modelli presentano almeno un bruciatore wok dual da 4.2 kW.

The AE burners (high efficiency) are state of the art and they guarantee up to 25% energy saving compared to standard burners. But they are also powerful. All models are designed with at least one wok Dual burner of 4.2 kW.



Caratteristiche piani induzione

Induction cooker hobs features



Il principio dell'induzione, come alternativa al più tradizionale blocco a gas, rende la linea dei blocchi Foster ancora più essenziale e pulita. Sono disponibili due distinte versioni: l'elegante modello con piano in linea a quattro zone e il performante 5 zone con funzionalità Bridge.

The induction concept, as an alternative to the more traditional gas range-top, endow the Foster tops with an even more streamlined design. Two versions: the elegant four in-line plates, and the high-performance 5 plates' with Bridge function.

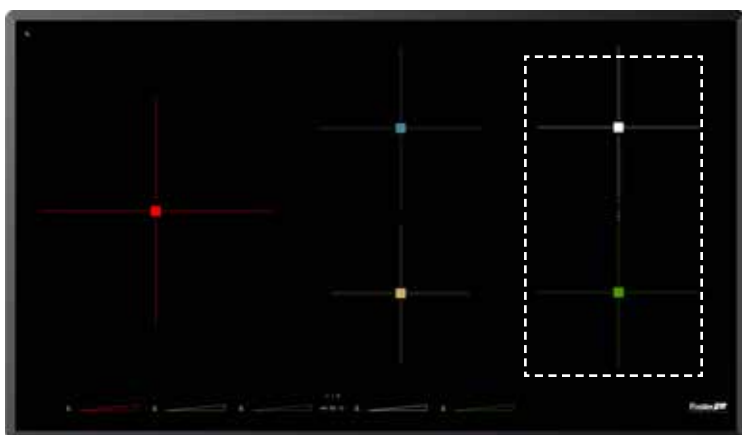

Cinque zone di cottura, grandi performance con una potenza fino a 3700W per zona grazie all'opzione Powerboost e tutta la flessibilità della zona estesa con funzione Bridge su cui alloggiare pentole di grandi dimensioni o per la cottura in contemporanea di più pietanze.

Five cooking plates, great performance with a power up to 3700W per plate, thanks to the Powerboost option, and all the flexibility granted by the Bridge function, on which to place large casseroles or to exploit for multiple preparations



Pratici comandi slider rendono veloci le regolazioni, mentre la funzione T-Chef permette l'impostazione puntuale delle temperature: 42°C per il mantenimento, 70° per pastorizzazione e bagnomaria, 94°C al punto di pre-ebollizione.

Practical slider controls grant quick and intuitive regulations, while the T-Chef function allows pinpoint temperature settings: 42°C to keep food warm, 70°C for pasteurization and bain-marie, 94°C as pre-boiling point.

Caratteristiche forni

Ovens features



Tutti i modelli presentano forni multifunzione con un variegato set di programmi con programmazione elettronica, e dimensioni fuori standard con un volume utile di ben 75 litri.

All models feature multifunctional ovens with a varied set of programs with electronic programming, and out of standard sizes with a useful volume of up to 75 liters.



La doppia guida telescopica, presente su tutti i modelli, permette l'estrazione di teglie e griglie con la massima facilità e sicurezza, una dotazione particolarmente comoda per un forno con dimensioni importanti.

The double telescopic guide, available on all models, allows to extract trays and grids with easy and safety; it is a particularly welcome equipment for an oven of large dimension.



Nei modelli 120 cm, l'ampio volume disponibile e lo sviluppo orizzontale della muffola permettono di sfruttare al meglio la dotazione del girarrosto per arrostitire con risultati professionali preparazioni anche di notevoli dimensioni.

On 120 cm models, the large available volume and wide cooking chamber allow a most functional use of the spit, for professional results even with large cuts of meat.



Four burners in line 120



Cucina free-standing in acciaio inox AISI 304 spazzolato

Dimensioni: 1200 x 650 x h 910 cm

Con banco attrezzato posteriore con 2 vaschette inox e due portabottiglie; Cassetto con chiusura ammortizzata; alzatina posteriore 20 mm; piedini regolabili a scomparsa.

Freestanding cooking centre in AISI 304 brushed stainless steel

Dimensions: 1200 x 650 x h 910 cm

With rear bench equipped with 2 stainless steel trays and two bottle holders; Drawer with damped closure; Rear backsrest 20 mm; Retractable adjustable feet

Cucina free-standing Free-standing cooking centre

codice - code

7154 000

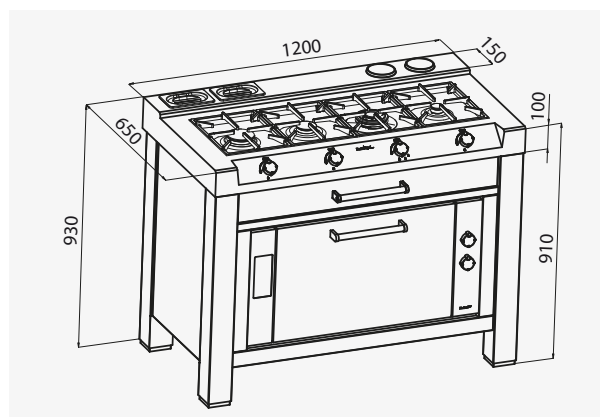

Blocco cottura a gas con 4 fuochi in linea

Manopole in acciaio inox satinato su banco frontale inclinato ergonomico. Griglie in ghisa e coprispartifiamma smaltati; Accensione elettrica; Valvolatura di sicurezza con termocoppia ad intervento rapido.

Potenza tot. 9.950 W
ausiliario: 1.000 W; semirapido: 1.750 W;
rapido: 3.000 W; dual: 4.200 W

Forno multifunzione 90x47 cm

Volume 73 litri
9 funzioni di cottura
Funzione girarrosto
Programmazione elettronica di inizio-fine cottura
Raffreddamento con ventilazione tangenziale
Guide telescopiche
Porta: 3 vetri
Cristallo StopSol
Smaltatura Easy Clean
Luce forno indipendente

Classe energetica: A
Alimentazione: 220-240 V 50 Hz

Dotazioni di serie:

Piano cottura: Elemento portawok in ghisa;

Forno: Griglia inox; Teglia con smaltatura EasyClean; Girarrosto; Pannello forno posteriore catalitico autopulente

Gas rangetop with four in-line burners

Brushed stainless steel knobs on ergonomic inclined front bench. Cast iron grids and enamelled burner covers; Electric ignition; Safety valves with ultra-rapid thermocouples.

Total Power 9,950 W
Auxiliary: 1,000 W; Semirapid: 1,750 W;
Fast: 3.000 W; Dual: 4,200 W

Multifunctional oven 90x47 cm

Volume 73 liters
9 cooking functions
Rotisserie function
Electronic programming of start and end of cooking
Cooling system with tangential ventilation
Telescopic guides
Door: 3 glasses
StopSol Crystal
Easy Clean enamelling
Independent oven light

Energy class: A
Power supply: 220-240 V 50 Hz

Standard equipment:

Hob: Cast iron wok support;

Oven: Stainless steel grill; EasyClean enamelled tray; Turnspit; Self-cleaning catalytic backplate.

Accessori/Accessories:

codice - code

8620 000



Modulo portaposate in legno

Wooden knife strain

codice - code

9401 506



Piastra refrattaria per pizza

Pizza refractory plate

codice - code

8800 012



Kit pannelli laterali autopulenti

Self-cleaning side panel kit

Six burners 120



Cucina free-standing in acciaio inox AISI 304 spazzolato

Dimensioni: 1200 x 650 x h 910 cm

Cassetto con chiusura ammortizzata; alzatina posteriore 20 mm; piedini regolabili a scomparsa.

Freestanding cooking centre in AISI 304 brushed stainless steel

Dimensions: 1200 x 650 x h 910 cm

Drawer with damped closure; Rear backsrest 20 mm; Retractable adjustable feet

Cucina free-standing Free-standing cooking centre

codice - code

7166 000

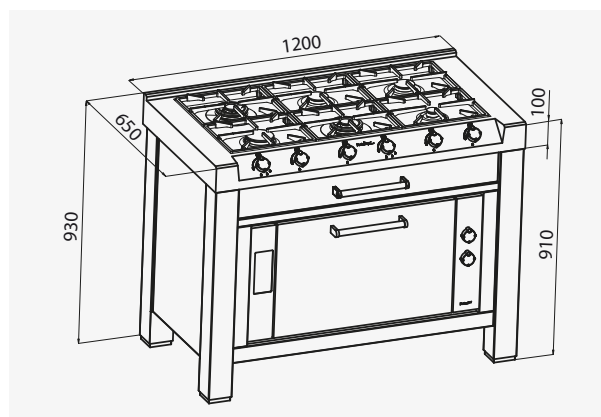

Blocco cottura a gas con 6 fuochi

Manopole in acciaio inox satinato su banco frontale inclinato ergonomico. Griglie in ghisa e coprispartifiamma smaltati; Accensione elettrica; Valvolatura di sicurezza con termocoppia ad intervento rapido.

Potenza tot. 15.900 W
ausiliario: 1.000 W, semirapido: 2x1.750 W,
rapido: 3.000 W, dual: 2x4.200 W

Forno multifunzione 90x47 cm

Volume 73 litri
9 funzioni di cottura
Funzione girarrosto
Programmazione elettronica di inizio-fine cottura
Raffreddamento con ventilazione tangenziale
Guide telescopiche
Porta: 3 vetri
Cristallo StopSol
Smaltatura Easy Clean
Luce forno indipendente

Classe energetica: A
Alimentazione: 220-240 V 50 Hz

Dotazioni di serie:

Piano cottura: Elemento portawok in ghisa;

Forno: Griglia inox; Teglia con smaltatura EasyClean; Girarrosto; Pannello forno posteriore catalitico autopulente.

Gas rangetop with six burners

Brushed stainless steel knobs on ergonomic inclined front bench. Cast iron grids and enamelled burner covers; Electric ignition; Safety valves with ultra-rapid thermocouples.

Total Power 15.900 W
auxiliary: 1.000 W, semirapido: 2x1.750 W,
fast: 3.000 W, dual: 2x4.200 W

Multifunctional oven 90x47 cm

Volume 73 liters
9 cooking functions
Rotisserie function
Electronic programming of start and end of cooking
Cooling system with tangential ventilation
Telescopic guides
Door: 3 glasses
StopSol Crystal
Easy Clean enamelling
Independent oven light

Energy class: A
Power supply: 220-240 V 50 Hz

Standard equipment:

Hob: Cast iron wok support;

Oven: Stainless steel grill; EasyClean enamelled tray; Turnspit; Self-cleaning catalytic backplate.

Accessori/Accessories:

codice - code

8620 000



Modulo portaposate in legno

Wooden knife strain

codice - code

9401 506



Piastra refrattaria per pizza

Pizza refractory plate

codice - code

8800 012



Kit pannelli laterali autopulenti

Self-cleaning side panel kit

Four burners 90



Cucina free-standing in acciaio inox AISI 304 spazzolato

Dimensioni: 900 x 650 x h 910 cm

Alzatina posteriore 20 mm; piedini regolabili a scomparsa.

Freestanding cooking centre in AISI 304 brushed stainless steel

Dimensions: 900 x 650 x h 910 cm

Rear backsrest 20 mm; Retractable adjustable feet

Cucina free-standing Free-standing cooking centre

codice - code

7162 000

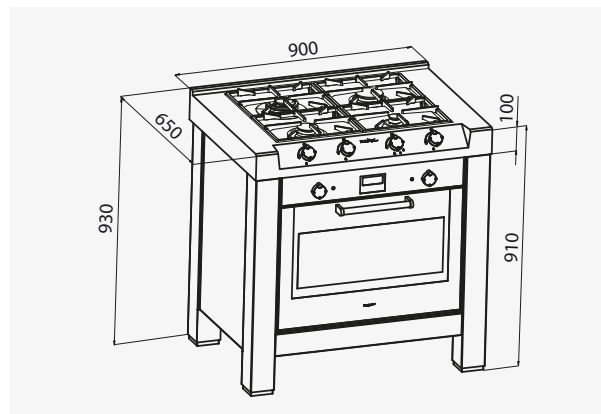

Blocco cottura a gas con 4 fuochi

Manopole in acciaio inox satinato su banco frontale inclinato ergonomico.
Griglie in ghisa e coprispartifiamma smaltati; Accensione elettrica; Valvolatura di sicurezza con termocoppia ad intervento rapido.

Potenza tot. 9.950 W
ausiliario: 1.000 W; semirapido: 1.750 W;
rapido: 3.000 W; dual: 4.200 W

Gas rangetop with four burners

Brushed stainless steel knobs on ergonomic inclined front bench.
Cast iron grids and enamelled burner covers; Electric ignition; Safety valves with ultra-rapid thermocouples.

Total Power 9,950 W
auxiliary: 1,000 W; semirapido: 1,750 W;
fast: 3,000 W; dual: 4,200 W

Forno multifunzione 70x60 cm

Volume 75 litri
8 funzioni di cottura
Programmazione elettronica di inizio-fine cottura
Raffreddamento con ventilazione tangenziale
2 Guide telescopiche
Porta: 3 vetri
Cristallo StopSol
Smaltatura Easy Clean
Luce forno indipendente

Classe energetica: C
Alimentazione: 220-240 V 50 Hz

Multifunctional oven 70x60 cm

Volume 75 liters
8 cooking functions
Electronic programming of start and end of cooking
Cooling system with tangential ventilation
2 Telescopic guides
Door: 3 glasses
StopSol Crystal
Easy Clean enamelling
Independent oven light

Energy class: C
Power supply: 220-240 V 50 Hz

Dotazioni di serie:

Piano cottura: Elemento portawok in ghisa;

Forno: 2 Griglie inox; Teglia con smaltatura EasyClean

Standard equipment:

Hob: Cast iron wok support;

Oven: Stainless steel grill; EasyClean enamelled tray;

Accessori/Accessories:

codice - code

9401 506



Piastra refrattaria per pizza

Pizza refractory plate



Four burners in line 120 - SPECIAL



Cucina free-standing in acciaio inox AISI 304 spazzolato

Dimensioni: 1200 x 650 x h 925 cm

Con banco attrezzato posteriore inclinato con 3 vaschette inox e portabottiglie; cassetto con chiusura ammortizzata; piedini regolabili a scomparsa.

Freestanding cooking centre in AISI 304 brushed stainless steel

Dimensions: 1200 x 650 x h 910 cm

With inclined rear bench equipped with 3 stainless steel trays and bottle holder; Drawer with damped closure; Retractable adjustable feet

Cucina free-standing Free-standing cooking centre

codice - code

7164 000

Prodotto disponibile a richiesta
Product available on request

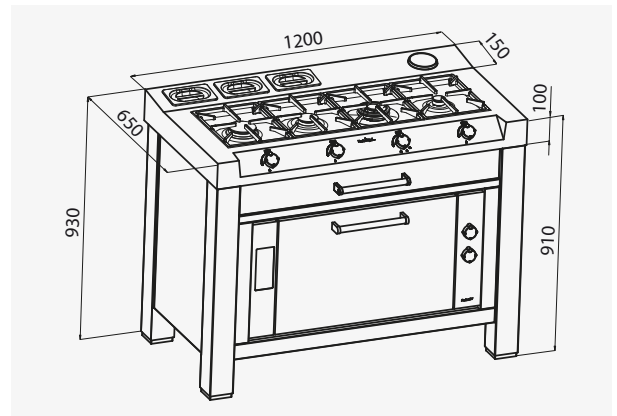

Abbinamenti/Matching:



Questa Cucina si abbinata al Centro lavaggio
7161 000 - a pag. 29

This kitchen combines with the washing center
7161 000 - p. 29

Blocco cottura a gas con 4 fuochi in linea

Manopole in acciaio inox satinato su banco frontale inclinato ergonomico.

Griglie in ghisa e coprispartifiamma smaltati; Accensione elettrica; Valvolatura di sicurezza con termocoppia ad intervento rapido.

Potenza tot. 9.950 W
ausiliario: 1.000 W; semirapido: 1.750 W;
rapido: 3.000 W; dual: 4.200 W

Forno multifunzione 90x47 cm

Volume 73 litri
9 funzioni di cottura
Funzione girarrosto
Programmazione elettronica
di inizio-fine cottura
Raffreddamento con ventilazione
tangenziale
Guide telescopiche
Porta: 3 vetri
Cristallo StopSol
Smaltatura Easy Clean
Luce forno indipendente

Classe energetica: A
Alimentazione: 220-240 V 50 Hz

Dotazioni di serie:

Piano cottura: Elemento portawok in ghisa;

Forno: Griglia inox; Teglia con smaltatura EasyClean; Girarrosto; Pannello forno posteriore catalitico autopulente.

Gas rangetop with four in-line burners

Brushed stainless steel knobs on ergonomic inclined front bench.
Cast iron grids and enamelled burner covers; Electric ignition; Safety valves with ultra-rapid thermocouples.

Total Power 9,950 W
auxiliary: 1,000 W; semirapido: 1,750 W;
fast: 3,000 W; dual: 4,200 W

Multifunctional oven 90x47 cm

Volume 73 liters
9 cooking functions
Rotisserie function
Electronic programming of start and end of cooking
Cooling system with tangential ventilation
Telescopic guides
Door: 3 glasses
StopSol Crystal
Easy Clean enamelling
Independent oven light

Energy class: A
Power supply: 220-240 V 50 Hz

Standard equipment:

Hob: Cast iron wok support;

Oven: Stainless steel grill; EasyClean enamelled tray; Turnspit; Self-cleaning catalytic backplate.

Accessori/Accessories:

codice - code

8620 000



Modulo portaposate
in legno

Wooden knife strain

codice - code

9401 506



Piastra refrattaria per
pizza

Pizza refractory plate

codice - code

8800 012



Kit pannelli laterali
autopulenti

Self-cleaning side
panel kit

Induction Four zones in line 120



Cucina free-standing in acciaio inox AISI 304 spazzolato

Dimensioni: 1200 x 650 x h 910 cm

Con banco attrezzato posteriore con 2 vaschette inox e due portabottiglie; Cassetto con chiusura ammortizzata; alzatina posteriore 20 mm; piedini regolabili a scomparsa.

Freestanding cooking centre in AISI 304 brushed stainless steel

Dimensions: 1200 x 650 x h 910 cm

With rear bench equipped with 2 stainless steel trays and two bottle holders; Drawer with damped closure; Rear backsrest 20 mm; Retractable adjustable feet

Cucina free-standing Free-standing cooking centre

codice - code

7165 000

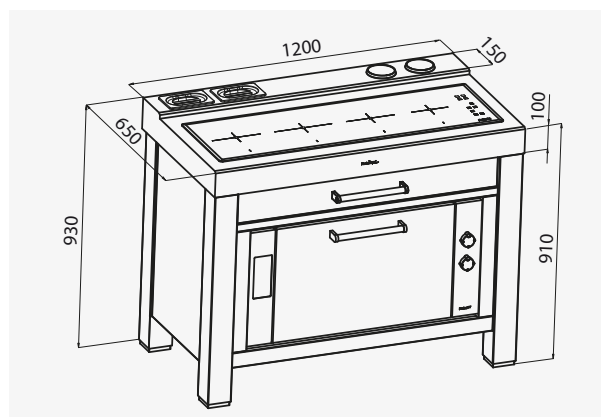

Alimentazione:
mono-fase 230V~1P+N
bi-fase 400V~2P+N
frequenza 50~60 Hz

Power supply:
single-phase 230V~1P+N
two-phase 400V~2P+N
frequency 50~60 Hz

Blocco cottura induzione con 4 zone in linea

Finitura: Vetroceramica nero programmazione elettronica; 9 settaggi di potenza per zona più doppio Powerboost; comandi touch control; timer indipendente; dotazioni di sicurezza

P. max assorbita 7.400 W
sinistra Ø 210 mm-2.050 (2.500)* (3.700)** W
sinistra centro Ø 210 mm-2.050 (2.500)* (3.700)** W
destra centro Ø 180 mm-1.850 (2.300)* (3.000)** W
destra Ø 180 mm-1.850 (2.300)* (3.000)** W
* Powerboost - **Doppio Powerboost

Induction rangetop with four in-line zones

Finishing: Black glass ceramic Electronic programming; 9 power settings per zone plus double Powerboost; Touch controls; Independent timer; Security equipment

P max absorbed 7,400 W
Left Ø 210 mm-2,050 (2,500) * (3,700) ** W
Left center Ø 210 mm-2,050 (2,500) * (3,700) ** W
Center right Ø 180 mm-1,850 (2,300) * (3,000) ** W
Right Ø 180 mm-1,850 (2,300) * (3,000) ** W
* Powerboost - ** Double Powerboost

Forno multifunzione 90x47 cm

Volume 73 litri
9 funzioni di cottura
Funzione girarrosto
Programmazione elettronica di inizio-fine cottura
Raffreddamento con ventilazione tangenziale
Guide telescopiche
Porta: 3 vetri
Cristallo StopSol
Smaltatura Easy Clean
Luce forno indipendente

Classe energetica: A
Alimentazione: 220-240 V 50 Hz

Multifunctional oven 90x47 cm

Volume 73 liters
9 cooking functions
Rotisserie function
Electronic programming of start and end of cooking
Cooling system with tangential ventilation
Telescopic guides
Door: 3 glasses
StopSol Crystal
Easy Clean enamelling
Independent oven light

Energy class: A
Power supply: 220-240 V 50 Hz

Dotazioni di serie:

Forno: Griglia inox; Teglia con smaltatura EasyClean; Girarrosto; Pannello forno posteriore catalitico autopulente.

Standard equipment:

Oven: Stainless steel grill; EasyClean enamelled tray; Turnspit; Self-cleaning catalytic backplate.

Accessori/Accessories:

codice - code

8620 000



Modulo portaposate in legno

Wooden knife strain

codice - code

9401 506



Piastra refrattaria per pizza

Pizza refractory plate

codice - code

8800 012



Kit pannelli laterali autopulenti

Self-cleaning side panel kit

Induction Five zones 120



Cucina free-standing in acciaio inox AISI 304 spazzolato

Dimensioni: 1200 x 650 x h 910 cm

Cassetto con chiusura ammortizzata; alzatina posteriore 20 mm; piedini regolabili a scomparsa.

Freestanding cooking centre in AISI 304 brushed stainless steel

Dimensions: 1200 x 650 x h 910 cm

Drawer with damped closure; Rear backsrest 20 mm; Retractable adjustable feet

Cucina free-standing Free-standing cooking centre

codice - code

7170 000

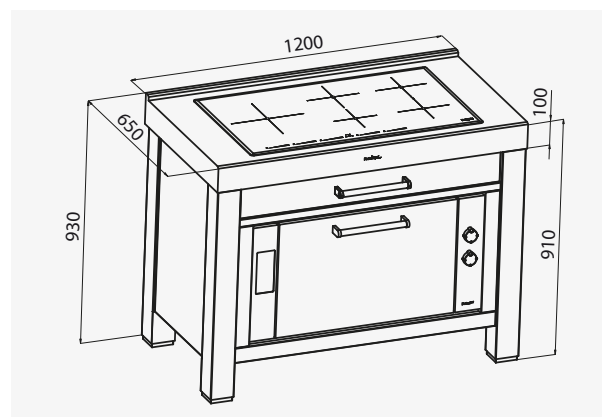

Alimentazione:
mono-fase 230V~1P+N
bi-fase 400V~2P+N
frequenza 50+60 Hz

Power supply:
single-phase 230V~1P+N
two-phase 400V~2P+N
frequency 50+60 Hz

Blocco cottura induzione con 5 zone

Finitura: Vetroceramica nero programmazione elettronica; funzione Bridge; 9 settaggi di potenza per zona più funzione Powerboost; comandi touch control; comando Slider; funzione T-Chef; automatismo go&stop; pausa; recall; dotazioni di sicurezza

P. max assorbita 11.100 W
sinistra Ø 260 mm-2.600 (3.700)* W
centro sup. Ø 180 mm-1.850 (3.000)* W
centro inf. Ø 145 mm-1.400 (2.200)* W
destra: 2x220x180 mm-2.100 (3.700)* W
* Powerboost

Forno multifunzione 90x47 cm

Volume 73 litri
9 funzioni di cottura
Funzione girarrosto
Programmazione elettronica di inizio-fine cottura
Raffreddamento con ventilazione tangenziale
Guide telescopiche
Porta: 3 vetri
Cristallo StopSol
Smaltatura Easy Clean
Luce forno indipendente

Classe energetica: A
Alimentazione: 220-240 V 50 Hz

Dotazioni di serie:

Forno: Griglia inox; Teglia con smaltatura EasyClean; Girarrosto; Pannello forno posteriore catalitico autopulente.

Induction rangetop with 5 zones

Finishing: Black glass ceramic
Electronic programming; Bridge function;
9 power settings per zone plus Powerboost function; Touch control; Slider control; T-Chef function; Go & stop function; break; recall; Security equipment

P. max absorbed 11,100 W
Left Ø 260 mm-2,600 (3,700) * W
Center sup. Ø 180 mm-1,850 (3,000) * W
Center inf. Ø 145 mm-1,400 (2,200) * W
Right: 2x220x180 mm-2,100 (3,700) * W
* Powerboost

Multifunctional oven 90x47 cm

Volume 73 liters
9 cooking functions
Rotisserie function
Electronic programming of start and end of cooking
Cooling system with tangential ventilation
Telescopic guides
Door: 3 glasses
StopSol Crystal
Easy Clean enamelling
Independent oven light

Energy class: A
Power supply: 220-240 V 50 Hz

Standard equipment:

Oven: Stainless steel grill; EasyClean enamelled tray; Turnspit; Self-cleaning catalytic backplate.

Accessori/Accessories:

codice - code

8620 000



Modulo portaposate in legno

Wooden knife strain

codice - code

9401 506



Piastra refrattaria per pizza

Pizza refractory plate

codice - code

8800 012



Kit pannelli laterali autopulenti

Self-cleaning side panel kit

Soluzioni Lavaggio *Washing Solutions*

Un centro di lavoro completo

Più di un livello.

Il blocco lavaggio di Foster è un pratico e completo centro funzionale dove, grazie a tanto spazio disponibile, alla grande vasca e un variegato set di accessori ogni operazione di preparazione diventa veloce, efficiente ed igienica.

A complete workstation

*More than a sink.
The Foster washing unit is
a practical and complete
functional centre on which,
thanks to the ample space, the
large bowl and the numerous
accessories, any preparation
becomes quick, efficient and
hygienic.*





Un'efficiente organizzazione degli spazi

Grazie ai due spaziosi cassettoni con chiusura ammortizzata, il centro lavaggio foster offre tanto spazio per poter riporre in modo pratico ed accessibile stoviglie, strumenti e detersivi. L'accessorio separatore consente inoltre di organizzare lo spazio in modo personalizzato.

Efficient space management

Thanks to the two spacious drawers with soft-closing mechanism, the Foster washing centre offers lots of space to store crockery, instruments and detergents in a practical and accessible way. The space within the unit can be customised using the supplied separating accessory.





Comoda raccolta differenziata

Tutti i modelli sono attrezzabili con un pratico sistema di raccolta differenziata con tre o quattro capienti ed eleganti pattumiere con coperchio inox. Tutto il pattume sparisce senza la necessità di altri bidoni esterni, spesso spiacevoli alla vista e all'olfatto.

Waste sorting made easy

All the models can be equipped with a practical waste sorting system with three or four elegant waste bins with stainless steel lid. All the waste can be treated without the use of external bins, often unsightly and smelly.

Miscelatori consigliati

Suggested mixer



GK

codice - code

8488 000



Tube

codice - code

8477 100



Spring

codice - code

8472 000



Maxi bowl GK 120



Blocco lavaggio free-standing in acciaio inox AISI 304 spazzolato

Dimensioni: 1200 x 650 x h 910 cm

AISI 304 Brushed stainless steel freestanding washing centre

Dimensions: 1200 x 650 x h 910 cm

Blocco lavaggio free-standing Free-standing washing centre

codice - code

7153 000

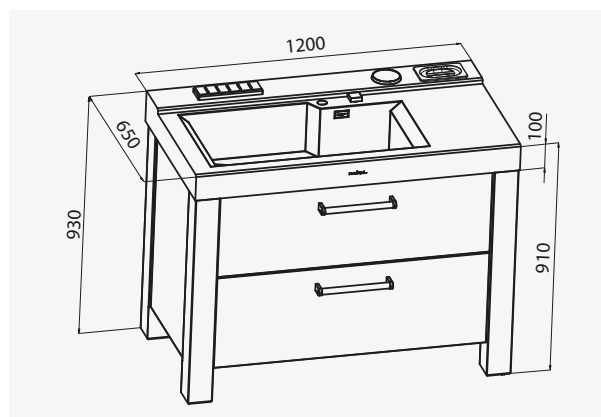

Vasca 73x50 cm / h 20 cm con piletta automatica Space con tappo inox; banco attrezzato posteriore con elemento portacoltelli in legno, vaschetta inox e portabottiglie. Due cassettoni con chiusura ammortizzata; alzatina posteriore 20 mm; piedini regolabili a scomparsa.

Bowl 73x50 cm / h 20 cm with Space automatic drain with stainless steel cap; Rear bench equipped with wooden knife strain, stainless steel container and bottle holder. Two drawers with dampened closure; Rear backrest 20 mm; Retractable adjustable feet.

Accessori/Accessories:

codice - code

8656 001



Tagliere scorrevole Iroko
Iroko chopping board

codice - code

8644 100



Tagliere Twin in HDPE
HDPE Twin chopping board

codice - code

8159 101



Kit grattugie con anello-supporto e vaschetta
Grating kit complete with ring support and food collection bowl

codice - code

8151 000



Vaschetta forata inox
St. steel perforated pan

codice - code

8100 303

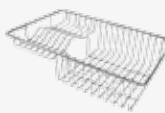

Cestello portapiatti inox 25x42,5 cm
St. steel dishes holder 25x42,5 cm

codice - code

8620 001

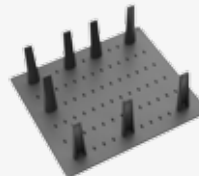

separatori portapiatti/pentole
Separators kit for plates and pots

codice - code

8146 000



sistema a quattro pattumiere per raccolta differenziata

Four bins system for separate waste collection

Maxi bowl GK 90



Blocco lavaggio free-standing in acciaio inox AISI 304 spazzolato

Dimensioni: 900 x 650 x h 910 cm

AISI 304 Brushed stainless steel freestanding washing centre

Dimensions: 900 x 650 x h 910 cm

Blocco lavaggio free-standing Free-standing washing centre

codice - code

7163 000

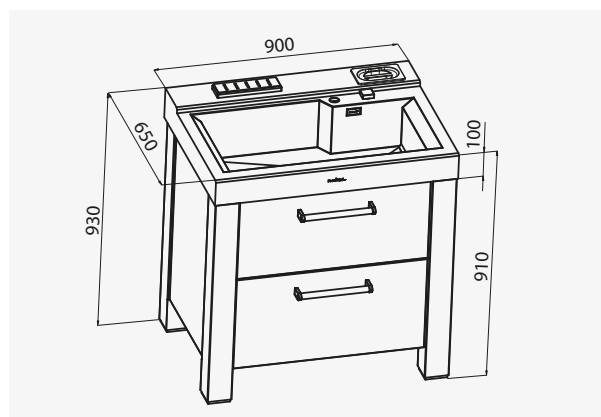

Vasca 73x50 cm / h 20 cm
con piletta automatica Space
con tappo inox;
banco attrezzato posteriore con
elemento portacoltelli in legno
e vaschetta inox.
Due cassettoni con chiusura
ammortizzata; alzatina posteriore
20 mm;
piedini regolabili a scomparsa.

*Bowl 73x50 cm / h 20 cm with
Space automatic drain with
stainless steel cap;
Rear bench equipped with wooden
knife strain and stainless steel
container.
Two drawers with dampened
closure;
Rear backrest 20 mm;
Retractable adjustable feet.*

Accessori/Accessories:

codice - code

8656 001



Tagliere scorrevole Iroko
Iroko chopping board

codice - code

8644 100



Tagliere Twin in HDPE
HDPE Twin chopping board

codice - code

8159 101



Kit grattugie con anello-
supporto e vaschetta
*Grating kit complete
with ring support and
food collection bowl*

codice - code

8151 000



Vaschetta forata inox
St. steel perforated pan

codice - code

8100 303

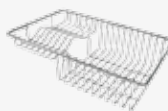

Cestello portapiatti inox
25x42,5 cm
*St. steel dishes holder
25x42,5 cm*

codice - code

8620 001

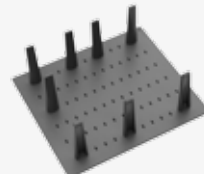

separatori portapiatti/
pentole
*Separators kit for plates
and pots*

codice - code

8146 001



sistema a tre pattumiere
per raccolta differenziata
*Three bins system for
separate waste collection*

Maxi bowl GK 120 - SPECIAL



Blocco lavaggio free-standing in acciaio inox AISI 304 spazzolato

Dimensioni: 1200 x 650 x h 910 cm

AISI 304 Brushed stainless steel freestanding washing centre

Dimensions: 1200 x 650 x h 910 cm

Vasca 73x50 cm / h 20 cm con piletta automatica Space con tappo inox; banco attrezzato posteriore inclinato con zona di scolo per piatti e bicchieri, vaschetta inox e portabottiglie. Due cassettoni con chiusura ammortizzata; piedini regolabili a scomparsa.

Bowl 73x50 cm / h 20 cm with Space automatic drain with stainless steel cap; Inclined rear bench equipped with, stainless steel drawer element, stainless steel container and bottle holder. Two drawers with dampened closure; Retractable adjustable feet.

Blocco lavaggio free-standing Free-standing washing centre

codice - code

7161 000

Prodotto disponibile a richiesta
Product available on request

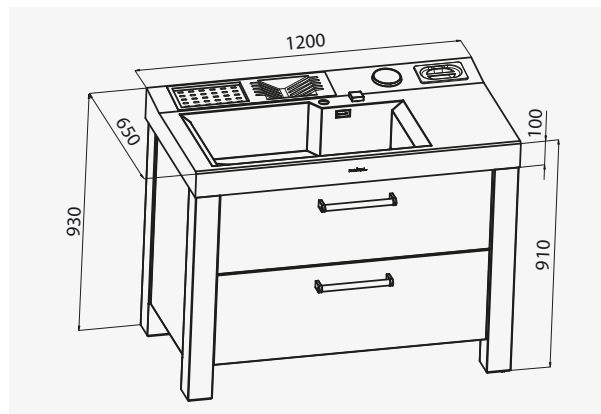

Abbinamenti/Matching:



Questo Centro lavaggio si abbina alla cucina 7164 000 - a pag. 18

This washing center combines with kitchen 7164 000 - p. 18

Accessori/Accessories:

codice - code

8656 001



Tagliere scorrevole Iroko
Iroko chopping board

codice - code

8644 100



Tagliere Twin in HDPE
HDPE Twin chopping board

codice - code

8159 101



Kit grattugie con anello-supporto e vaschetta
Grating kit complete with ring support and food collection bowl

codice - code

8151 000



Vaschetta forata inox
St. steel perforated pan

codice - code

8100 303

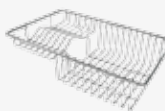

Cestello portapiatti inox 25x42,5 cm
St. steel dishes holder 25x42,5 cm

codice - code

8620 001

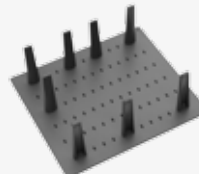

separatori portapiatti/pentole
Separators kit for plates and pots

codice - code

8146 000



sistema a quattro pattumiere per raccolta differenziata

Four bins system for separate waste collection

Aspirazione Aspiration



Cappe Florence - Florence Hoods



Cappe aspiranti in acciaio inox AISI 304

AISI 304 Stainless steel aspiring hoods

codice - code | dimensione - dimension

2538 090 **90 cm**

2538 120 **120 cm**

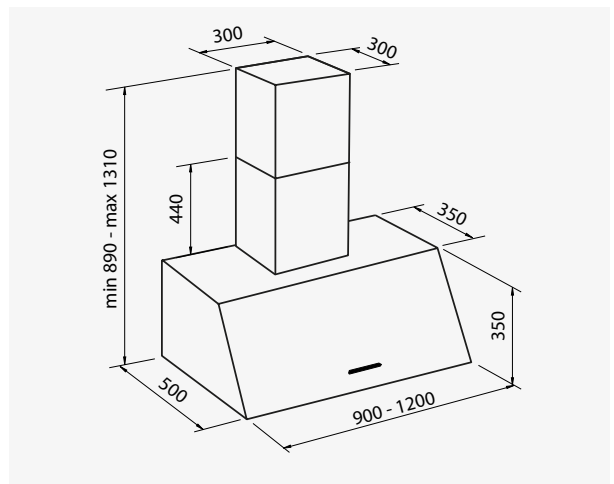

Spessore acciaio: 1 mm
 Motore Silent Plus
 Portata: 1000 m³/h
 Filtri antigrasso in acciaio inox
 Florence 90: 3 filtri
 Florence 120: 4 filtri
 Spegnimento automatico ritardato
 Allarme di saturazione filtri
 Illuminazione Led:
 Florence 90 (2 led x 2,1W)
 Florence 120 (3 led x 2,1W)
 Temperatura di colore led: 4000K
 Quattro velocità di esercizio
 Pannello East Cleaning
 Sistema di aspirazione bilanciata
 Funzionamento filtrante opzionale
 con filtri carbone
Classe Energetica A+

Steel thickness: 1 mm
Silence Plus Motor
Air flow rate: 1000 m³/h
Stainless steel filters
Florence 90: 3 filters
Florence 120: 4 filters
Automatic delay shutdowd
Saturation filters alarm
LED lighting
Florence 90 (2 led x 2,1W)
Florence 120 (3 led x 2,1W)
Led Light temperature 4000K
4 speeds
Easy cleaning panel
Balanced Aspiration System
Optional filtering mode
with carchoal filter kit
Energy Calss A+

Foster management system
is ISO 9001:2008 certified

Registration number CH-36474



Tutti i prodotti Foster sono conformi alle direttive CEE
e sono coperti da garanzia Foster per 24 mesi.

*All Foster products conform to the EEC directive and
are covered by the Foster 24-month warranty.*

Foster declina ogni responsabilità per eventuali
inesattezze ed errori e si riserva il diritto di apportare
modifiche e migliorie ai prodotti illustrati in qualsiasi
momento senza preavviso.

*The features are purely guideline. We reserve the right to
modify them at any moment without notice.*



freestanding



ognidove

Foster 
Live the Quality

Foster spa - Via M. S. Ottone, 18/20 - 42041 Brescello (Re) Italy - E-mail: info@fosterspa.com

www.fosterspa.com